

PIVOT 2.0

Parts Included:

1. Chassis
2. Male Pin
3. Female Pin
4. Spring Washer
5. D-Ring
6. Spacers

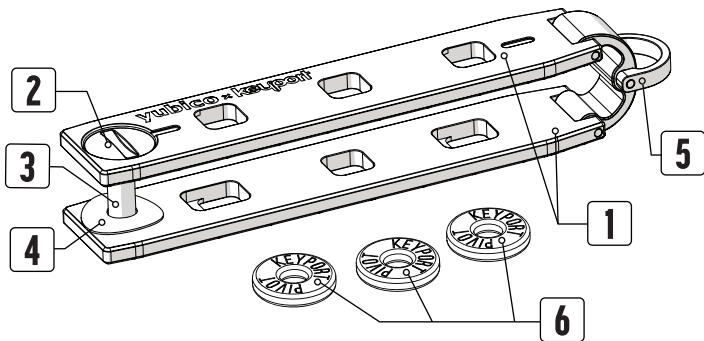

ASSEMBLY INSTRUCTIONS:

1. Remove Male Pin & lay open on table as shown
2. Stack up to eight keys & tools on top of Spring Washer

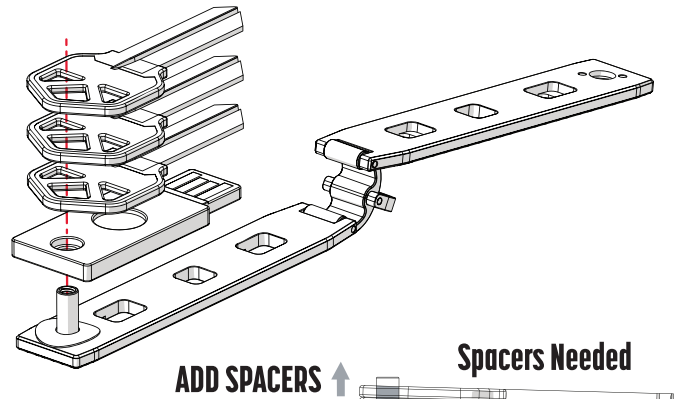

Spacers Needed

IMPORTANT

Stack must be at least one key or spacer height above Female Pin

OK

Good Examples

OK

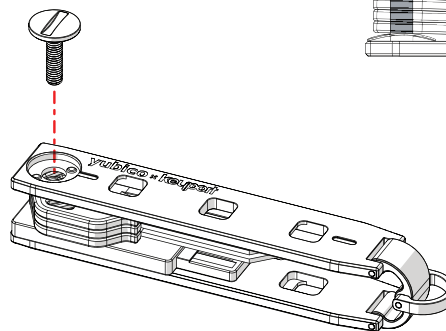

For purchase & setup instructions
yubico.com/product/pivot2

3. Hold stack firmly on table while folding loose Chassis over
4. Align holes & install Male Pin - tighten with coin